

## Solid State Control for Bi-Directional Motors



ON Semiconductor®

<http://onsemi.com>

### APPLICATION NOTE

#### INTRODUCTION

Some split phase motors are able to operate in forward and reverse directions since they have two windings for these purposes. Depending on which winding is energized, the motor operates in that direction. These motors are especially used in applications for washing machines, transport belts, and all kinds of equipment in which the operation in both directions is needed. One of the most traditional way to control these kind of motors is through mechanical relays. Nevertheless, they have a lot of disadvantages which make them ineffective.

This paper is going to show how triacs can substitute the function of the mechanical relays for controlling bi-directional motors offering a higher level of quality and reliability for control purposes.

The triac is a three terminal ac semiconductor switch that is triggered into conduction when a low energy signal is applied to its gate. Unlike the silicon controlled rectifier or SCR, the triac will conduct current in either direction when turned on. The triac also differs from the SCR in that either a positive or negative gate signal will trigger the triac into conduction. The triac may be thought of as two complementary SCRs in parallel.

The triac offers the circuit designer an economical and versatile means of accurately controlling ac power. It has several advantages over conventional mechanical switches.

Since the triac has a positive 'on' and a zero current 'off' characteristics, it does not suffer from the contact bounce or arcing inherent in mechanical switches. The switching action of the triac is very fast compared to conventional relays, giving more accurate control. A triac can be triggered by dc, ac, rectified ac or pulses. Because of the low energy required for triggering a triac, the control circuit can use any of many low cost solid state devices such as transistors, sensitive gate SCRs and triacs, optically coupled drivers, and integrated circuits.

#### DEFINITIONS

The two-phase induction motor consists of a stator with two windings displaced 90 electrical degrees from each other in space and squirrel cage rotor or the equivalent. The ac voltages applied to the two windings are generally phase displaced from each other 90° in time. When the voltages magnitudes are equal, the equivalent of balanced two-phase voltages is applied to the stator. The resultant stator flux is then similar to a three-phase induction motor. The motor torque speed curves are also similar to those of a three-phase motor. The two-phase control motor is usually built with a high resistance rotor to give a high starting torque and a dropping torque speed characteristic.

The following schematic diagram shows an ac split phase motor:

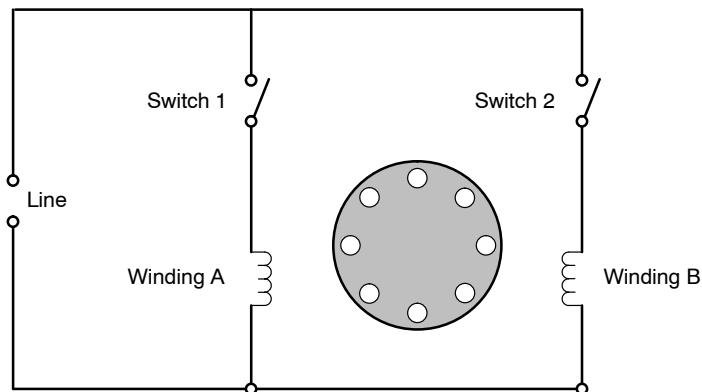

## AND8017/D

If switch 1 is activated, rotation in one direction is obtained; if switch 2 is activated, rotation in the other direction results. Since the torque is a function of the voltage supply, changing the magnitude of this changes the developed torque of the motor. The stalled torque is assumed to be linearly proportional to the rms control-winding voltage.

It is very common to add a resonant L-C circuit connected between the motor windings in order to damp the energy stored by each motor winding inductance, avoiding

damage to the switches when the transition from one direction to the other occurs. In addition, this resonant L-C circuit helps to have good performance in the motor's torque each time it changes its rotation.

The following schematic diagram shows how two triacs can control the rotation of a split phase motor depending in which winding is energized. In this case the motor selected for analysis purposes has the following technical characteristics: 230Vrms, 1.9 Arms, 1/4 Hp, 60Hz, 1400 RPM.

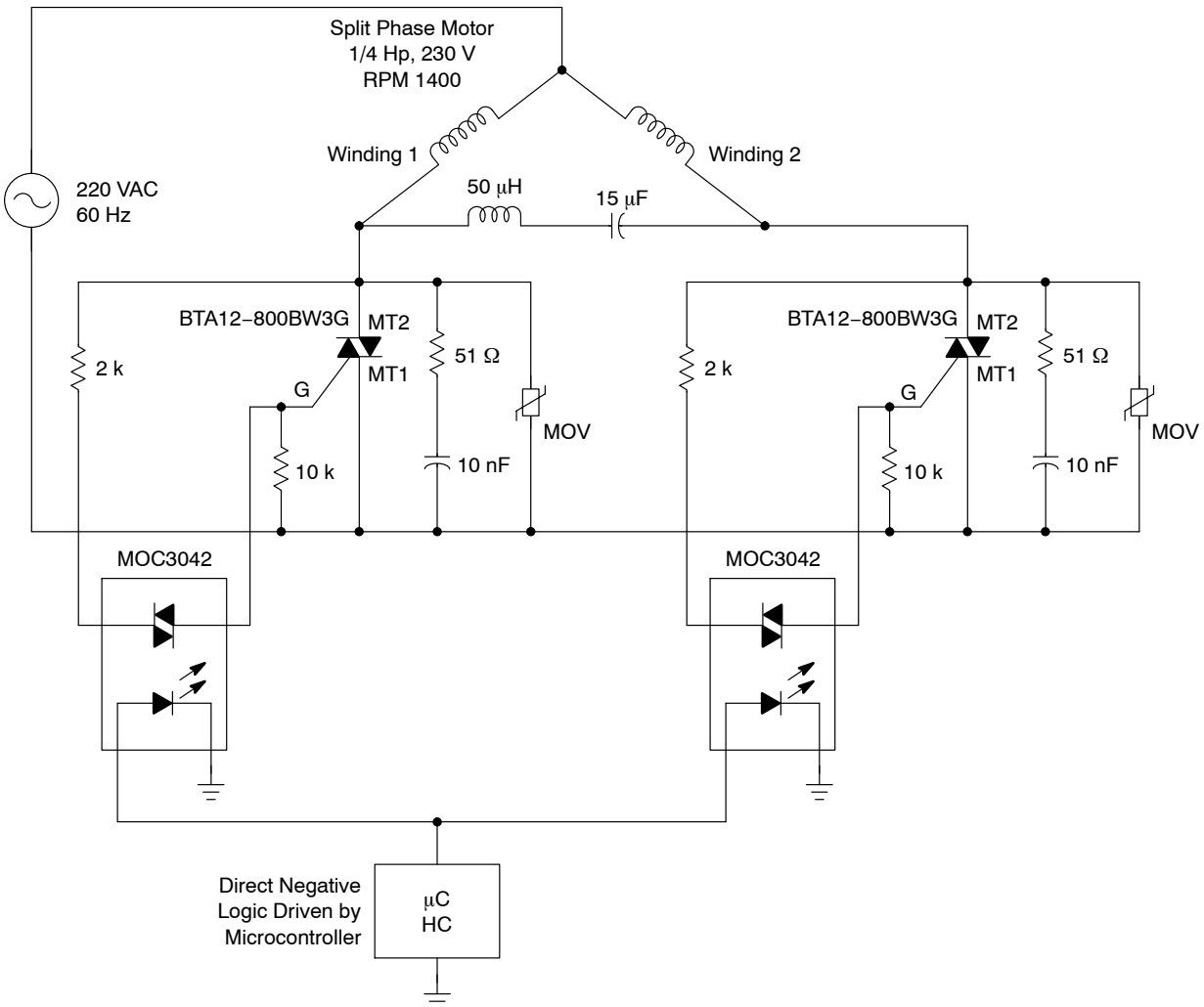

The micro is controlling the trigger of the triacs through optocouplers (MOC3042). The optocoupler protects the control circuitry (Microcontroller, Logic Gates, etc.) if a short circuit condition occurs within the power circuitry since these optocouplers insulate the control part of the general circuit. The MOVs protects the triacs against to the high voltage transients caused because of the motor rotation changes, so it is very important to add them in the power circuit, otherwise the triacs could be damaged easily. The snubber arrangement provides protection against dV/dt conditions occurring within the application circuit and the resonant L-C circuit connected between the motor's wind-

ings helps to have good performance in the torque of the motor when it changes its rotation.

In the case that the motor is locked due to some mechanical problem within the application field, the maximum current peak flowing through the triacs would be 7.2 Amps (5.02 Amps rms), therefore, the triacs (BTA12-800BW3G) would not be damaged since they are able to handle up to 12 A rms.

Nevertheless, it is recommended to add an overload protector in the power circuit of the motor in order to protect it against any kind of overload conditions which

## AND8017/D

could damage the motor in a short period of time since the current flowing would be higher than its nominal value.

In conclusion, it has been shown how triacs (BTA12-800BW3G) substitute the mechanical relay's functions to control bi-directional motors offering many important advantages like reliable control, quiet operation, long life span, small size, light weight, fast operation, among others. These are only some of the big advantages that can be obtained if thyristors are used to control bi-directional motors. Besides, the total cost of the electronic circuitry does not exceed to the cost of the conventional mechanical relays.

A very important consideration is that extreme environment temperatures could affect the functionality of the electronic devices, therefore, if operation under extreme ambient temperatures is needed, the designer must take into consideration the parameter variation of the electronic devices in order to establish if any kind of adjustment is needed within the electronic circuitry.

Another important item to be considered by the designer is that the triacs have to be mounted on a proper heatsink in order to assure that the case temperature of the device does not exceed the specifications shown in the datasheet.

**ON Semiconductor** and  are registered trademarks of Semiconductor Components Industries, LLC (SCILLC). SCILLC reserves the right to make changes without further notice to any products herein. SCILLC makes no warranty, representation or guarantee regarding the suitability of its products for any particular purpose, nor does SCILLC assume any liability arising out of the application or use of any product or circuit, and specifically disclaims any and all liability, including without limitation special, consequential or incidental damages. "Typical" parameters which may be provided in SCILLC data sheets and/or specifications can and do vary in different applications and actual performance may vary over time. All operating parameters, including "Typicals" must be validated for each customer application by customer's technical experts. SCILLC does not convey any license under its patent rights nor the rights of others. SCILLC products are not designed, intended, or authorized for use as components in systems intended for surgical implant into the body, or other applications intended to support or sustain life, or for any other application in which the failure of the SCILLC product could create a situation where personal injury or death may occur. Should Buyer purchase or use SCILLC products for any such unintended or unauthorized application, Buyer shall indemnify and hold SCILLC and its officers, employees, subsidiaries, affiliates, and distributors harmless against all claims, costs, damages, and expenses, and reasonable attorney fees arising out of, directly or indirectly, any claim of personal injury or death associated with such unintended or unauthorized use, even if such claim alleges that SCILLC was negligent regarding the design or manufacture of the part. SCILLC is an Equal Opportunity/Affirmative Action Employer. This literature is subject to all applicable copyright laws and is not for resale in any manner.

### PUBLICATION ORDERING INFORMATION

#### LITERATURE FULFILLMENT:

Literature Distribution Center for ON Semiconductor  
P.O. Box 5163, Denver, Colorado 80217 USA  
**Phone:** 303-675-2175 or 800-344-3860 Toll Free USA/Canada  
**Fax:** 303-675-2176 or 800-344-3867 Toll Free USA/Canada  
**Email:** [orderlit@onsemi.com](mailto:orderlit@onsemi.com)

**N. American Technical Support:** 800-282-9855 Toll Free  
USA/Canada  
**Europe, Middle East and Africa Technical Support:**  
Phone: 421 33 790 2910  
**Japan Customer Focus Center**  
Phone: 81-3-5773-3850

**ON Semiconductor Website:** [www.onsemi.com](http://www.onsemi.com)

**Order Literature:** <http://www.onsemi.com/orderlit>

For additional information, please contact your local Sales Representative